

欢迎使用 TAKSTAR® 便携式数字扩音器。本产品是专为教学、导游培训、健身、娱乐等场合的扩音应用而设计。采用数字控制技术、集多种功能于一体，是您工作和娱乐的好助手。在使用之前，请仔细阅读本说明书，以便能正确的操作，发挥本扩音器的理想性能。

产品特性

- 集麦克风、功放、FM收音机、音箱、充电器、电池为一体的便携式多媒体扩音器
- 具有音乐播放功能，支持TF存储卡及U盘热插拔
- 内置FM收音功能，可自动搜索电台及保存多个频道
- 内置大容量耐久型锂离子电池，为该产品提供高电能的同时，减少废弃物的产生
- 采用A/B类模拟功放，音质清晰逼真，峰值输出功率达15W
- 内置MCU充电管理系统，具有双重放电保护功能，使电池工作安全可靠
- 7.4V 2000mAh锂电池供电，充电只需5小时，使用时间约为10小时
- 具有LINE IN 音频输入接口，可外接MP3、CD等音频设备
- 产品使用人体工学原理设计，造型新颖，外观时尚，使用舒适

控制面板功能示意图

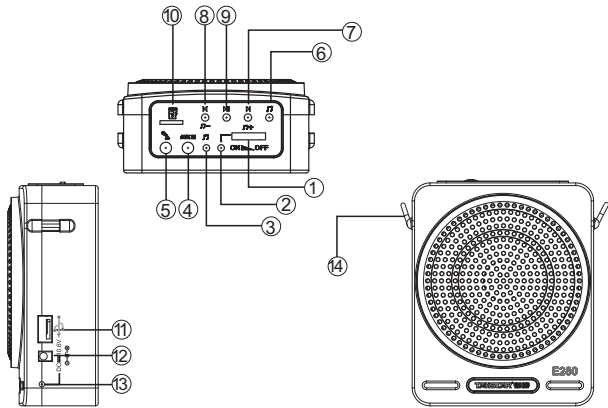

- ① 电源开关和音量调整旋钮：向左转动旋钮，听到“嘀”一声，表示扩音器已通电，此时电源指示灯②亮，继续向左转动旋钮声音越大，反之，声音越小直至关机
- ② 电源指示灯：当扩音器通电时，此灯会亮。绿灯表示高电压，红灯表示低电压，当此灯亮红灯时，请及时为电池充电
- ③ 音乐播放指示灯：在插入TF卡播放音乐时，指示灯红灯闪烁；音乐暂停时，指示灯常亮红色，音乐关闭时，指示灯熄灭
- ④ AUX IN插孔：用ø3.5mm插头的音频线将DVD、MP3等音乐信号导入本机可做有源音箱使用。在收音状态下，将头戴插入此孔可以做天线使用
- ⑤ 麦克风输入插孔：将ø3.5mm的麦克风插头插入此孔，进入扩音工作状态；操作时，请不要将麦克风的拾音面朝向扩音器的扬声器，以免产生啸叫
- ⑥ 音乐功能切换按键：按 **||** 键可以控制音乐的播放开关，麦克风在上述模式中同步使用；按 **||** 键还能切换到收音模式，在此模式中应将麦克风插入AUX IN 孔内充当天线作用。
- ⑦ 音量功能按键：**||**、**||+** 短按为下一曲，长按此键可以单独增大音乐播放音量满足讲解时做背景音乐；在收音模式中，按 **||** 选下一频道
- ⑧ 音量功能按键：**||-**、**||-** 短按为上一曲，长按此键可以单独调小音乐播放音量满足讲解时做背景音乐；在收音模式中，按 **||-** 选上一频道

- ⑨ 播放/暂停按键：按 **||** 键可以控制音乐的播放和暂停；在收音模式中，长按 **||** 进行自动搜索，此时音乐指示灯③闪烁绿色，当频道选定时，音乐指示灯③会常亮绿色
- ⑩ TF 内存卡插口：根据标识方向插入存有音乐文件的TF内存卡。插入时，听到“嗒”一声，表示已安装到位并将其锁住；取卡时只需将卡往下轻按，听到“嗒”一声，TF内存卡会自动弹出
- ⑪ U盘插孔：将存放有音乐文件的U盘插入此孔
- ⑫ 充电输入插孔：将随机配送的10.6V/450mA电源充电器插头插入此孔，即可开始对电池充电
- ⑬ 充电指示灯：将充电器插入 ⑫ 孔内，指示灯亮红色，表示电池进入充电状态；指示灯由红色变为绿色后，表示电已充满
- ⑭ 肩挂扣

技术参数

额定输出功率: 10W
 峰值输出功率: 15W
 音乐格式: MP3
 频率响应: 100Hz-12KHz
 扬声器阻抗: 4Ω
 使用时间: 约10小时
 充电时间: 约5小时
 充电器规格: DC 10.6V/450mA
 电池规格: 7.4V/2000mAh锂离子电池
 产品规格: 125 × 100 × 55mm
 产品重量: 400g

使用与注意事项

- 在收音机模式下，需将头戴麦克风音频线插入AUX IN插座，充当接收天线使用，并尽量展开线缆，通过调整不同的方向可获得理想的收音效果。
- 为了达到良好的效果，请对准头戴的咪芯（1-2cm）处发音。
- 将头戴麦克风正确的佩戴在头部，并调整好麦克风的拾音角度，以防方向不正引起啸叫。
- 请根据实际使用空间适当调整音量大小，以获取理想使用效果。
- 长时间不使用时应将电池充满电，以确保电池的使用寿命。
- 请不要将外部音源信号（如DVD、MP3等）从MIC插孔输入，以免声音幅度过大而失真。
- 为了确保充电器的理想性能，请使用本机配送的DC 10.6V/450mA专用充电供电。
- 非专业技术人员请不要擅自拆机改装或维修；如有问题或服务需求请联系当地经销商。

标准配置



适用场合

教学、导游、聚会、售货、宣传、参观等场合扩音用。

特殊要求：请先关机后再充电！

Welcome to use TAKSTAR portable digital voice amplifier. This product is ideal for teaching, tour guide, morning exercise, entertainment etc. because of the excellent digital technology, long battery playtime and high output power. Please read this user manual detailedly before using to make sure the correct operation.

Features

- A/B type analog amplifier features clear sound reproduction and high output power up to 15W
- Music play function supports multimedia audio file play of USB flash disk and TF card
- Built-in FM function to search for TV station and save multi-channel
- Built-in MCU intelligent recharging management system for secure battery charging and discharging, fast charging time is about 5hrs and long playtime is about 10hrs
- Audio input socket for connecting MP3, CD
- Unique and fashionable design

Function Illustration

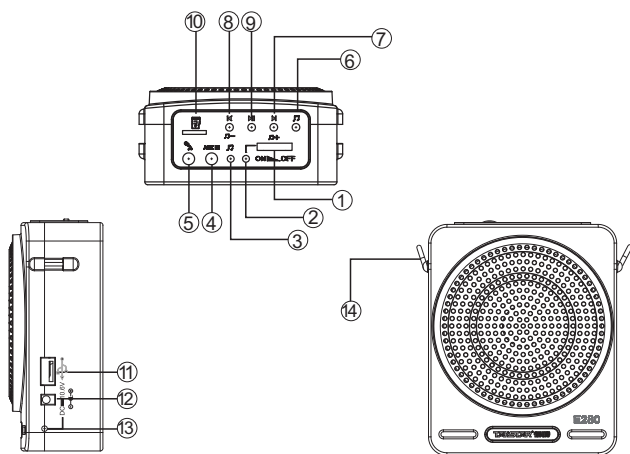

- ① Power switch with volume control: Turn the wheel ① to the left until you hear a clicking sound “Di”, the amplifier is now switched on and the power LED ② will light, turn left for louder voice, turn right for lower voice until power off.
- ② Power indicator: It will light green when the amplifier is power-on. If the battery voltage is low, it will turn red, please recharge the battery in time.
- ③ Music play indicator: It will glitter when playing the music and turns red when pause, when stop playing the music, it will be off.
- ④ Aux input socket: Use the audio cable supplied by the amplifier to connect the music signal such as DVD, MP3 with the amplifier. Under FM mode, insert the headset to this socket for using as an antenna.
- ⑤ Microphone input socket: Insert the microphone $\Phi 3.5\text{mm}$ plug into this socket. When speaking, do not point the microphone directly to amplifier, or it will cause howling.
- ⑥ Music play function switching button: Press \blacktriangleleft can turn on/off the music, the microphone can be used at the same time. Press \blacktriangleleft can also switch to FM mode, you should insert the microphone to AUX IN socket for using as an antenna.
- ⑦ Press \blacktriangleleft , $\blacktriangleleft+$ for next song, press \blacktriangleleft , $\blacktriangleleft+$ long for music volume increase to meet the demand of background music when speaking. When under FM mode, press \blacktriangleleft for next channel.
- ⑧ Press \blacktriangleright , $\blacktriangleright-$ for previous song, press \blacktriangleright , $\blacktriangleright-$ long for music volume reduction to meet the demand of background music when speaking. When under FM mode, press \blacktriangleright for previous channel.

- ⑨ Press \blacktriangleleft for play/pause the music. When it is under FM mode, press \blacktriangleleft long for searching channel automatically, indicator ③ will green glitter, when the channel is confirmed, indicator ③ will permanently light green.
- ⑩ TF card port: Please insert the TF card according to the direction of the illustration, when you hear “DA” after you insert it, it means the card is fixed; when you want to take out the card, just press it and the card will come out automatically.
- ⑪ USB port: Plug in the USB disk which has stored the music files.
- ⑫ Recharging input socket: Input the 10.6V/450mA power adapter plug to this socket for recharging.
- ⑬ Recharging indicator: Insert the charger to ⑫ socket, when it is being recharged, it is red; after full recharging, it is green.
- ⑭ Hanging buckle

Specification

Rated Output Power: 10W
 Max. Output Power: 15W
 Media Format: MP3
 Frequency Response: 100Hz-12kHz
 Output Impedance: 4 Ω
 Playtime: about 10hrs
 Recharging Time: about 5hrs
 Power Adapter: DC 10.6V/450mA
 Battery Specification: 7.4V/2000mAh lithium-ion battery
 Product Dimension: 125×100×55mm
 Net Weight: 400g

Operation & Caution

1. When it is under FM mode, you should insert the headworn microphone into AUX IN socket for using as an antenna and max expand the cable, adjusting different direction can get excellent radio effect.
2. Aim at the headworn mic capsule when speaking and keep the distance between vocal and mic as 1-2cm to avoid howling.
3. Wear the headworn microphone correctly and adjust the suitable microphone pick-up angle.
4. Adjust the volume according to the actual space size.
5. When long time no use, fully recharge the battery to assure the battery life time, and then take out the battery.
6. Don't insert external audio signal such as DVD or MP3 into the MIC socket to avoid distortion due to extreme high voice.
7. In order to assure excellent performance for charger, pls. use DC 10.6V/450mA special power adapter supplied with this voice amplifier.
8. Non-special technician is not allowed to disassemble or repair the product, please contact the local agent if there is any question or service requirement.

Standard Configuration



Application

Teaching, tour guiding, outdoor activity, selling, morning exercise, entertainment.

Special Requirement: Please turn off the amplifier before charging.