

# GH520

电竞头戴耳机

GAMING HEADSET



  
自由玩家™  
LIBERTY GAMER

用户手册  
USER MANUAL

## ■ 前言

尊敬的用户：

欢迎使用自由玩家 GH520 电竞头戴耳机，为了您能够更好地了解我们的产品，建议您在使用前仔细阅读本说明书。若您存在疑问或愿意提供宝贵建议，可通过拨打得胜官方服务热线400 6828 333或微信扫描二维码关注自由玩家官方公众号与我们联系。



## ■ 产品特性

- 提供7.1虚拟环绕声，声场宽广，带给您声临其境的游戏体验；
- Ø50mm超大驱动单元，灵敏度高，带给您多频段的出色音质表现；
- 约1680万RGB灯效，变色幻彩，为您带来十足电竞现场氛围感受；
- 免调节人体工程学头梁设计，结构轻巧，给您无压力佩戴的酣畅游戏；
- 可插拔高灵敏度麦克风，一键静音，带给您便捷的游戏对话交流功能；
- 采用弹性头梁与网布透气耳罩，不压耳朵，带来久戴不累的轻巧感受。

## ■ 包装清单

电竞头戴耳机 .....	1只
分离式麦克风 .....	1只
Type-C 连接线 .....	1条
3.5mm连接线 .....	1条
USB转接器 .....	1个
用户手册 .....	1份

## ■ 适用范围

PC、MAC、PS4、PS5、Xbox One、Xbox Series、Nintendo Switch、VR、手机、平板

## ■ 系统要求

Windows7及以上、OS X 10.9及以上

## ■ 技术参数

单元:动圈式

单元直径:Ø50mm

单体阻抗:32Ω±15%

耳机频率响应:20Hz-20kHz

耳机灵敏度:94±3dB(3.5mm);96±3dB(USB/Type-C)

额定功率:20mW

峰值功率:25mW

麦克风指向性:全指向

麦克风灵敏度(单体):-38±3dB

Type-C连接线:Ø4mmX2.2m

3.5mm连接线:Ø4mmX2.2m

USB转接器:USB-A转Type-C

连接类型:Type-C/USB/3.5mm



产品重量:约305g

注:以上数据由得胜实验室测试得到,并拥有最终解释权!

## ■ 使用说明

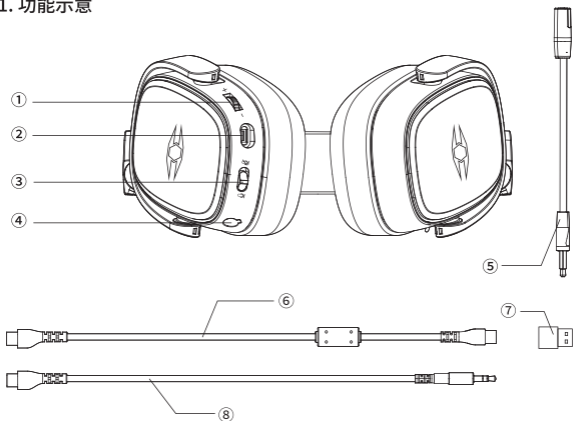
### 1. 功能示意



- ① 音量调节旋钮:往“+”方向转动旋钮为增大音量  
往“-”方向转动旋钮为减小音量
- ② 耳机连接线接口 (Type-C)
- ③ 麦克风静音开关:前拨至“”为麦克风开启,后拨至“”为麦克风静音
- ④ 麦克风接口
- ⑤ 分离式麦克风
- ⑥ Type-C连接线
- ⑦ USB转接器
- ⑧ 3.5mm 连接线

## 2. 可拆卸麦克风

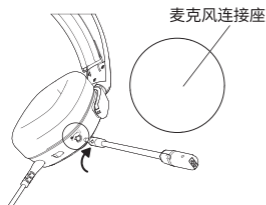

### ① 麦克风的安装

向内插入麦克风，顺时针旋转至“”，锁定麦克风；

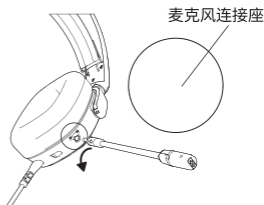

### ② 麦克风的拆卸

逆时针旋转至“”，向外拔出麦克风。

## 3. 设备连接

### ① Type-C终端

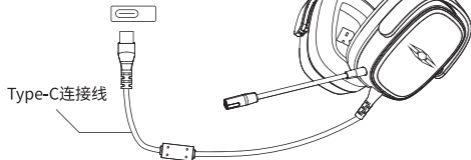
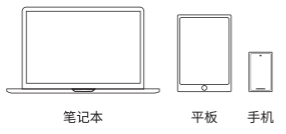

使用Type-C连接线连接，插入设备Type-C接口

设置：Windows、Mac设置方向USB终端设置方法；部份移动设备需手动打开OTG功能，根据设备提示或进入系统设置进行对应的音频输出设备。

## ② USB终端

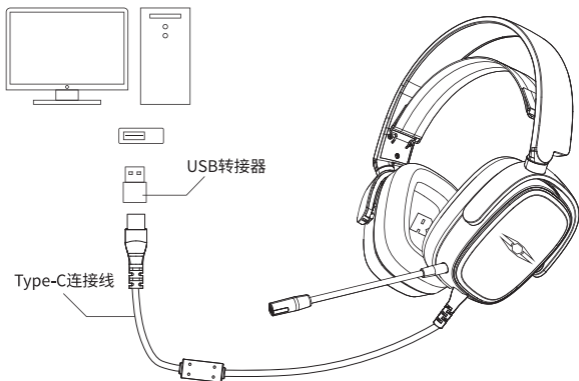

使用Type-C连接线与USB转接器连接后,插入设备USB接口

注意: USB接口需使用高功率端口(USB2.0及以上),旧式键盘和显示器上的USB端口可能不支持高功率设备。

## ③ 3.5mm终端

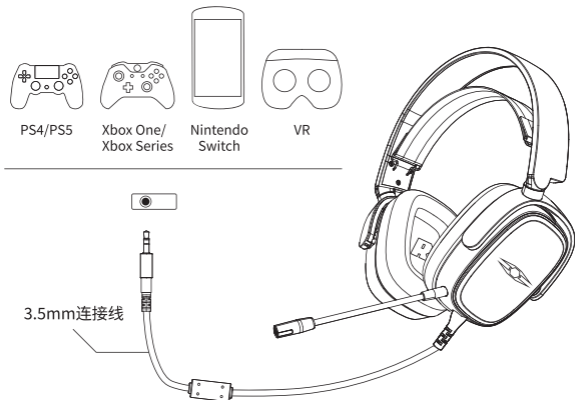

注意：兼容CTIA标准接口设备。

## 4. 驱动安装

请访问[www.libertygamer.com](http://www.libertygamer.com) 下载驱动程序；

使用驱动程序可以启用耳机的全套功能：

耳机音频设置

麦克风音频设置

7.1环绕声设置

（适用于运行Windows7及以上操作系统的PC上安装）

注意：要启用7.1环绕，需安装驱动程序开启7.1环绕声，否则耳机默认为立体声模式工作。

## 5. 设置

Windows:

从“控制面板”/“硬件和声音”/“声音”，将“播放”和“录制”选择卡分别选择“LIBERTY GAMER-GH520”



Mac:

从“系统偏好设置”/“声音”，将“输出”和“输入”设备选择卡选择“LIBERTY GAMER-GH520”





## ■ 安全使用说明

为了您有一个安全与舒适的体验,请仔细阅读并遵守以下事项:

1.为了避免听力受损,请务必在连接耳机前将播放设备音量调小!在将耳机佩戴入耳内/耳上之后,再逐步调大至您聆听舒适的音量。噪音是以分贝(dB)为计量单位,外界任何85分贝及以上的噪音都会导致听力逐渐受损。

2.请注意您的使用习惯!音量与时间对听力的损伤是成正反比的关系,音量越大,您聆听的时间越短;音量越舒适,您聆听的时间越长。长时间使用较高的音量会对您的听力造成损伤。

以下分贝(dB)表对某些常见声音进行比较,并列出了他们可能对听力的潜在危害等级:

声音来源	噪声等级	听力影响
细声低语	30dB	非常安静
安静的办公室	50-60dB	舒适的听力级别在60dB以下
吸尘器/吹风机	70dB	有一定入侵性,造成干扰妨碍电话交谈
食物料理机	85-90dB	85dB是开始造成听力受损(连续8小时)的级别
垃圾清理机 混凝土搅拌机	100dB	建议无保护措施而暴露在90-100dB声音之下的时间不要超过15分钟
电锯/电钻	110dB	经常暴露于超过100dB的声音1分钟以上会有听力受损的风险
摇滚音乐会 (因情况而异)	110-140dB	感觉疼痛的阈值在120dB左右开始

## ■ 维护及保养

- 1.耳机的额定功率20mW，请不要超负荷使用，以免造成耳机损坏；
- 2.请储存于干燥洁净环境，使用中避免液体进入耳机内部、跌落或碰撞，以免损坏；
- 3.勿在高温高湿的场所长时间使用耳机，容易造成耳机损坏或降低使用寿命；
- 4.耳机在放置时要避免与强磁体接触，以免耳机的恒磁体去磁，使耳机的灵敏度降低而影响影响耳机音色；
- 5.勿使用烈性化学制品、清洁剂，清洁耳机；
- 6.不要用尖锐物品在产品表面刚蹭，以免损坏外壳，影响外观；
- 7.耳机长时间不使用时，应存放在干燥清洁的地方，避免在温度过高或过度潮湿的场所保管或使用；
- 8.请不要自行拆机改装或维修，以防止出现人身伤害，如有问题或服务需求请联系当地经销商跟进处理。

## ■ 注意事项

### ⚠ 危险

• 为确保您的人身安全，请勿将该耳机佩戴或放置在离心脏起搏器过近的位置（小于10cm）。	⊘ 禁止
• 请勿将线材插头插入电源插座。	⊘ 禁止
• 为了您与其他交通参与者的安全，驾驶机动车、骑自行车或马路上行走时，请勿使用耳机。	❗ 执行
• 请勿将耳机靠近明火或置于火中，以免发生爆炸。	⊘ 禁止

### ⚠ 警告

• 儿童应在成人监督下使用本产品，本产品并非玩具。	❗ 执行
• 使用该产品时需遵守相关安全规定，法律法规明确禁止使用场合请勿使用本机，以免导致意外事故。	❗ 执行

## ■ 关于图标含义解释

 根据RL2004/108/EG和European Low Voltage Directive (欧洲低电压指令) RL2006/95/EG的测试结果表明,本产品符合欧共同体关于电磁兼容性的成员国法律整合的指令中所规定的限值。

 未经合规方明确批准的变更或修改可能会使用户失去操作设备的权限。此设备符合FCC规则第15条部分的要求。操作须符合以下两个条件:

- (1) 此设备可能不会造成有害干扰;
- (2) 此设备必须接受接收到的任何干扰,包括可能导致意外操作的干扰。

 此符号表示,根据WEEE指令(2012/19/EU)和国家法律,由于这种类型的废弃物会有潜在的有害物质,可能对环境 and 人类健康产生负面影响,所以本产品不应与您的家庭垃圾一起处置,应将本产品交由授权的电气和电子设备(WEEE)回收站回收。同时,您在正确处理本产品的同时将有助于自然资源的利用。如需了解更多有关您可以在何处放置废物回收设备的信息,请有效联系您当地的城市办事处、废物管理局或家庭废物处理服务部门。

## ■ 关于本说明书

本说明书中内容符合截止印刷之日的技术规格。由于得胜公司会不断改进产品，本说明书可能不符合您的特定产品的技术规格。要获取最新版说明书，请访问自由玩家官网，然后下载说明书文件。技术规格、设备或另售的附件在各个地区可能有所不同，如有问题请与当地自由玩家经销商确认。如需更多支持和深层产品信息，请浏览自由玩家官方网站：[www.libertygamer.com](http://www.libertygamer.com)

## ■ Preface

Dear Customer,

Thank you for purchasing Liberty Gamer GH520 Gaming Headset. In order to better understand and use the product, please read this manual carefully. If you have any questions or suggestions, please contact our local dealer.

## ■ Features

- 7.1CH virtual surround to expand and bring you the ultimate gaming immersion
- Responsive 50mm mega driver pumps out excellent audio across the spectrum
- About 16.8 million RGB colors to light up the vibes
- Adjust-free lightweight ergonomic headband to wear through long gaming sessions
- Sensitive detachable mic to start/stop in-game chatting anytime in one touch
- Elastic head strap and air-permeable mesh earpads for stress-free use

## ■ Package Contents

Gaming Headset .....	1PC
Detachable Mic .....	1PC
Type-C Cable .....	1PC
3.5mm Cable .....	1PC
USB Adapter .....	1PC
User Manual .....	1PC

## ■ Application

PC, Mac, PS4, PS5, Xbox One, Xbox Series, Nintendo Switch, VR, smartphone, tablet

## ■ System Requirements

Windows7 or above, OS X 10.9 or later

## ■ Specifications

- Driver: dynamic
- Driver Diameter:  $\varnothing 50\text{mm}$
- Driver Impedance:  $32\Omega \pm 15\%$
- Headset Frequency Response: 20Hz-20kHz
- Headset Sensitivity:  $94 \pm 3\text{dB}$  (3.5mm) ;  $96 \pm 3\text{dB}$  (USB/Type-C)
- Rated Power: 20mW
- Peak Power: 25mW
- Mic Directivity: Omni-directional
- Mic Sensitivity:  $-38 \pm 3\text{dB}$
- Type-C Cable:  $\varnothing 4\text{mm} \times 2.2\text{m}$
- 3.5mm Cable:  $\varnothing 4\text{mm} \times 2.2\text{m}$
- USB adapter: USB-A to Type-C
- Connector Type: Type-C/USB/3.5mm
- Weight: about 305g

Note: The above data are measured by Takstar laboratory, and Takstar has the final interpretation right!

## ■ Operation Instructions

### 1. Function Description

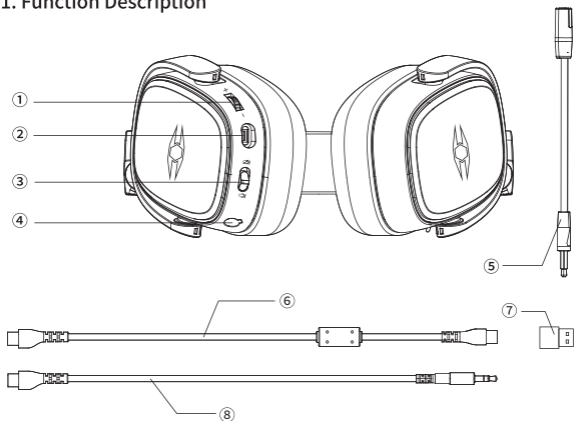

- ① Volume Knob: turn towards [+] to increase volume level,  
or towards [-] to decrease
- ② Headset Cable Port (Type-C)
- ③ Mic Mute Switch: slide forward to enable microphone, or backward  
to disable microphone
- ④ Mic Port
- ⑤ Detachable Mic
- ⑥ Type-C Cable
- ⑦ USB Adapter
- ⑧ 3.5mm Cable



## 2. Detachable Microphone

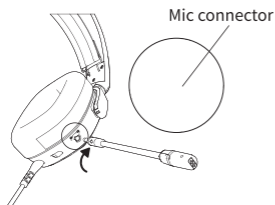

### ① Installing Mic

Insert mic and rotate clockwise to locked position.

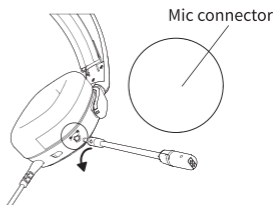

### ② Detaching Mic

Rotate mic counterclockwise to unlocked position and pull out.

## 3. Device Connection

### ① Type-C Terminal

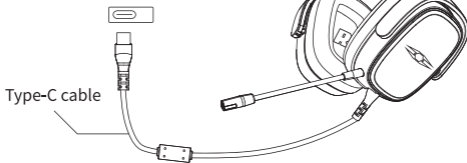
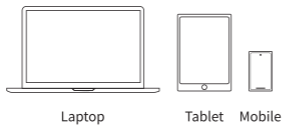

Connect the Type-C cable and insert into the Type-C port of the device.  
System Settings: For Windows and Mac settings, same as that for USB terminal above. You may need to manually enable the OTG function on some mobile devices; follow the device prompt or go into system settings to select corresponding audio output device.

## ② USB Terminal

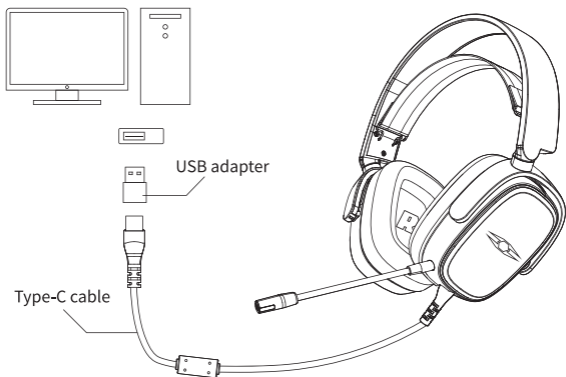

Connect the Type-C cable to the USB adapter, and the adapter to the USB port of the device.

Note: The USB port should be a high power interface (USB2.0 or above).  
USB ports on old-style keyboard and display may not support high-power devices.

## ③ 3.5mm Terminal

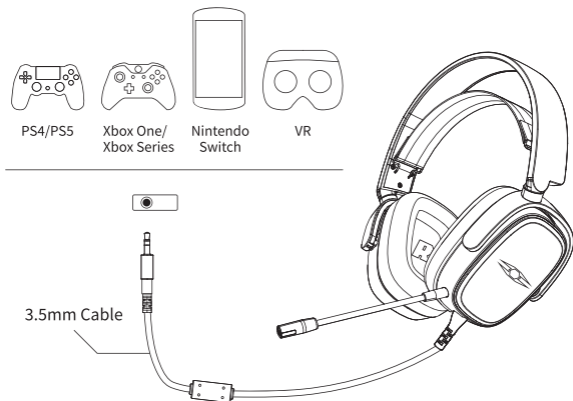

Note: compatible with standard CTIA devices.

## 4. Driver Installation

Please download the driver from [www.libertygamer.com](http://www.libertygamer.com)

By using the driver software, you can gain full access to:

Headset audio settings

Microphone audio settings

7.1 Surround settings

(Can be installed on PC running Windows 7 or later)

Note: To use 7.1 Surround, you must enable it in the driver software. Otherwise the headset uses stereo mode by default.

## 5. System Settings

Windows:

navigate to Control Panel → Hardware and Sound → Sound, and set “LIBERTY GAMER-GH520” as default device under both Playback and Recording tabs.

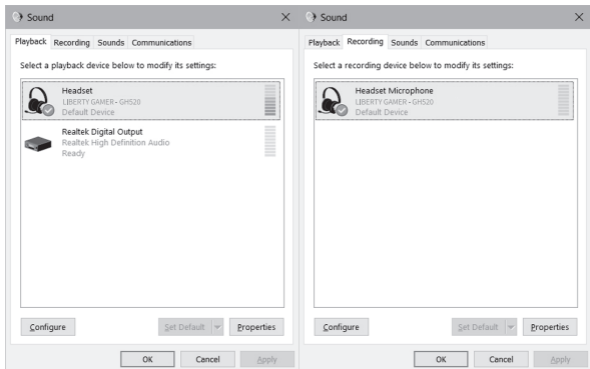

Mac:

navigate to System Preferences → Sound, and select “LIBERTY GAMER-GH520” under both Output and Input tabs.

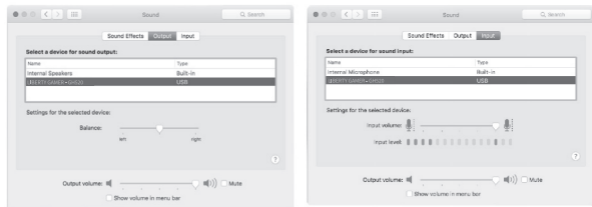

## ■ Correct Operation

For safe and comfortable operation, please read carefully and abide by the following items:

1. To avoid hearing loss, set the volume of the player to minimum before connecting the headset. After putting the earphone on, increase the volume to a proper level. Noise is measured in decibels (dB). Any outside noise of 85 decibels or more will cause gradual hearing loss.
2. Please pay attention to your operation habits! Volume and duration are proportional to hearing loss. The higher the volume, the shorter the time you should listen; the more comfortable the volume is, the longer you can listen. Listening at high volume for long will cause damage to your hearing. This dB level chart compares some common noise sources and their potential danger to your hearing:





Sound Source	Noise Level	Consequence on Hearing
Whisper	30dB	Very quiet
Quiet office	50-60dB	Comfortable hearing level is below 60dB
Vacuum cleaner /hair dryer	70dB	Somewhat invasive and may interfere with phone calls
Food processor	85-90dB	85dB (continuously 8 hours) will begin to hurt hearing
Garbage cleaning machine/ cement mixer	100dB	Exposure to sound of 90~100dB is suggested to be within 15 minutes if without protection
Electric saw /electric drill	110dB	Frequent exposure to over 100dB for more than 1 minute can impair hearing
Rock concert (subjective)	110-140dB	Painful hearing starts at about 120dB

## ■ Maintenance



1. The rated power of this headset is 20mW. Please do not operate it at overload status to avoid damage.
2. Please keep it in a dry and clean environment. During operation, prevent damage from water ingress, drop or collision.
3. Operating the headset in high temperature or high humidity for long can lead to device damage or shortened service life.
4. Keep the headset away from strong magnet to avoid demagnetizing and decreased sensitivity and performance.
5. Do not use strong chemical or detergent for cleaning.
6. Do not scratch the product surface with sharp objects.
7. Store in a clean, dry area if not used for a long period. Keep and use away from areas of high temperature and humidity.
8. Do not disassemble or repair the product by yourself to avoid injury. If you have any questions or require any services, please contact our local seller.

## ■ Cautions

### DANGER

<ul style="list-style-type: none"><li>• To ensure your personal safety, do not wear or place the headset too close to the pacemaker (less than 10cm).</li></ul>	 Prohibition
<ul style="list-style-type: none"><li>• Do not insert the cable plug into live power socket.</li></ul>	 Prohibition
<ul style="list-style-type: none"><li>• For your safety and the safety of other traffic participants, do not use the headset while driving a vehicle, riding a bicycle or walking on the road.</li></ul>	 Implementation
<ul style="list-style-type: none"><li>• Keep away from fire to avoid explosion.</li></ul>	 Prohibition

### WARNING

<ul style="list-style-type: none"><li>• Not a toy. Children should not use without adult supervision.</li></ul>	 Implementation
<ul style="list-style-type: none"><li>• Abide by relative safety rules during operation. Do not use it if prohibited by laws and regulations to avoid accident.</li></ul>	 Implementation

## ■ Label Meanings

**CE** This device is compliant with the limits of the European Council Directive on the approximation of the laws of the member states relating to electromagnetic compatibility according to RL2004/108/EG and European Low Voltage Directive RL2006/95/EG.

**FCC** Changes or modifications not expressly approved by the complying party may cause the user to lose permission to operate the device.

This device complies with part 15 of the FCC Rules. Operation is subject to the following two conditions:

- 1) This device may not cause harmful interference, and
- 2) This device must accept any interference received, including interference that may cause undesired operation.

 This symbol indicates that this product should not be disposed of with your household waste, according to the WEEE directive (2012/19/EU) and your national law. This product should be handed over to an authorized collection site for recycling waste electrical and electronic equipment (WEEE). Improper handling of this type of waste could have a possible negative impact on the environment and human health due to potentially hazardous substances that are generally associated with WEEE. At the same time, your cooperation in the correct disposal of this product will contribute to the effective usage of natural resources. For more information about where you can drop off your waste equipment for recycling, please contact your local city office, waste authority, or your household waste disposal service.



## ■ About This Manual

This manual contains up-to-date technical specifications as of printing. However, specifications contained herein may not conform to your particular product since Liberty Gamer is constantly improving its products. Also, specifications, devices or accessories available may vary from region to region. If you have any questions, please contact our local dealer. For the latest version/more information, please visit our website: [www.libertygamer.com](http://www.libertygamer.com)

**产品中有毒有害物质或元素的名称及含量标识表**

部件名称	有毒有害物质或元素					
	铅 (Pb)	汞 (Hg)	镉 (Cd)	六价铬 (Cr(VI))	多溴联苯 (PBB)	多溴二苯醚 (PBDE)
塑料部件	○	○	○	○	○	○
金属部件	×	○	○	○	○	○
电路板组件	×	○	○	○	○	○
线缆	×	○	○	○	○	○

本表格依据SJ/T 11364的规定编制。

○：表示该有害物质在该部件所有均质材料中的含量均在 GB/T 26572 规定的限量要求以下。

×：表示该有害物质至少在该部件的某一均质材料中的含量超出 GB/T 26572 规定的限量要求。

此标志为产品的环保使用期限标志，

且此环保使用期限只适用于产品正常工作的温度和湿度等条件。



## 注意事项:

1. 本单为保修凭证, 请用户妥善保管, 如有遗失, 恕不保修或退换。
2. 保修期限制: 购买之日起十二个月内。
3. 除了不可抗力事件损坏外, 由本公司负责, 免费维修。
4. 如属保管不善或使用不当造成的损坏, 维修点将酌情收费。
5. 擅自拆卸维修者, 不予保修。
6. 以上保修条款仅限于中国市场适用 (不含港澳台地区)。

# 产品服务保证书

姓名: \_\_\_\_\_ 电话: \_\_\_\_\_ 地址: \_\_\_\_\_

商品: \_\_\_\_\_ 型号: \_\_\_\_\_ 购买日期: \_\_\_\_\_ 年 \_\_\_\_\_ 月 \_\_\_\_\_ 日

维修记录栏 (由维修员填写)	维修员签名	日期



**广东省电声工程技术研究开发中心  
广东得胜电子有限公司制造**

地址：广东省惠州市博罗县龙溪街道富康一路2号

全国服务热线：400 6828 333

邮箱：liberty.gamer@takstar.com

网址：www.libertygamer.com

Guangdong Takstar Electronic Co., Ltd.

Address: No. 2 Fu Kang YiRd., Longxi Boluo

Huizhou, Guangdong 516121 China

Tel: 86 752 6383644 Fax: 86 752 6383952

Email: sales@takstar.com

Website: www.libertygamer.com

GB 8898-2011  
9TGH520S1A