

# TAKSTAR® 得胜



## WPM-500 无线监听耳机

WPM-500 Wireless Monitor Headphones

使用手册 | User Manual

# WPM-500 无线监听耳机

## ■ 前言

尊敬的用户：

感谢您选购得胜WPM-500无线监听耳机，为了您能够更好的了解使用本产品，建议您在使用前仔细阅读本说明书。



若存在有疑问或者您有宝贵的建议，可通过拨打得胜官方服务热线400 6828 333或微信扫描二维码关注得胜官方公众号与我们联系。

## ■ 产品特性

- 一款颈挂式无线监听耳机，专为直播监听、录音监听等场合设计；
- 采用2.4G无线传输技术，连接和传输信号稳定，可达10米传输距离；
- 无线一拖多，可实现N个耳机同步监听，一键配对，多人分享；
- 专业录音级别，低延迟，音画同步，直播互动更流畅；
- 快速配对，自动回连，无需繁琐的配对操作；
- 48KHz采样率，立体声高清音质，音乐细节饱满动感；
- 耳机采用绕耳式设计，小巧轻便，佩戴舒适，载歌载舞轻松自如；
- 发射器采用Φ3.5mm音频输入接口，方便与声卡、调音台等音频设备连接；
- 内置锂电池，持久续航，充电2小时，可持续使用约6-8小时。

## ■ 包装清单

WPM-500无线耳机 .....	1副
WPM-500发射器 .....	1个
USB充电线 .....	1条
耳机延长线 .....	1条
转接头 .....	1个
硅胶套塞 .....	3对
说明书 .....	1份

# WPM-500 无线监听耳机

---

## ■ 适用范围

直播监听、录音监听、直播带货等场合

## ■ 技术参数

### 发射器参数

- 电池容量：聚合物锂电池 3.7V/450mAh
- 电池充电时间：约2.5小时
- 充电电压/电流：DC 5V/300mA
- 传输频率：2.4GHz
- 工作续航时间：约6小时（电池满电时）
- 重量：22g

### 接收器参数

- 电池容量：聚合物锂电池 3.7V/240mAh
- 电池充电时间：约2.5小时
- 充电电压/电流：DC 5V/200mA
- 工作续航时间：约8小时（电池满电时）
- 频率范围：20Hz-20KHz
- 传输频率：2.4GHz
- 重量：33g

### 综合参数

- 低延迟距离： $\geq 10$ 米
- 声音延迟： $\leq 20$ ms
- 频响范围：20Hz-20KHz(1KHz基准-3dB)
- 信噪比： $\geq 80$ dB(A+)
- 系统底噪： $\leq 90$ dB(A+)

注：以上数据由得胜实验室测试得到，并拥有最终解释权！

### ■ 功能示意

#### 耳机发射器

- ① 电源键：长按电源键2秒，开启或关闭耳机发射器；  
开机时，指示灯②蓝灯长亮，关机时，指示灯②蓝灯熄灭；
- ② 指示灯：充电时，指示灯长亮红灯；  
满电时，指示灯红灯熄灭；  
低电量状态下，指示灯红灯闪烁；  
长按配对键蓝灯快闪，表示处于对频状态，配对完成后蓝灯恢复长亮；
- ③ 配对键：开机状态下，长按配对键2秒，进入配对模式。

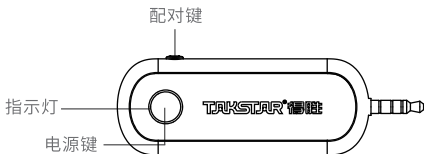

#### 无线耳机

- ① 电源键：长按电源键2秒，开启或关闭耳机；
- ② 指示灯：开机状态下，进入自动回连模式，同时指示灯蓝灯慢闪，回连成功后指示灯蓝灯恢复长亮；  
长按配对键蓝灯快闪，表示处于对频状态，配对完成后蓝灯恢复长亮；
- ③ 配对键：开机状态下，长按配对键2秒，进入配对模式；
- ④ 音量调节键：点按“+”键增加耳机监听音量，长按“+”键持续增加音量；  
点按“-”键减小耳机监听音量，长按“-”键持续减小音量，共10级音量可调。

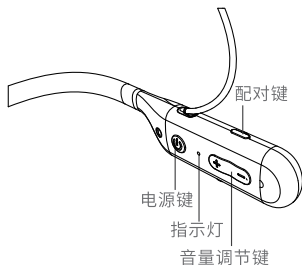

## 发射器与耳机配对方法：

出厂时已默认配对好，开机会自动连接，无需配对；如单独更换了发射器或耳机，可按照如下方法重新配对：

- ① 分别打开无线耳机及发射器电源开关；
- ② 分别长按无线耳机及发射器配对键2秒进入配对模式，同时指示灯蓝灯快闪；待指示灯蓝灯恢复长亮，则表示对频成功。

注：当产品出现配对连接异常时，请接入Type-c充电线，同时按住电源键和配对键，即可进行系统复位。

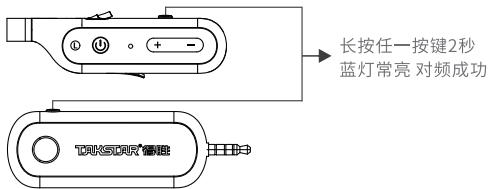

## WPM-500 无线监听耳机

### 直播监听：

1. 发射器与耳机配对成功后，先将配备的3.5mm转6.3mm转接头一端插入声卡的耳机接口；
2. 然后将发射器插入转接头的另一端，即可进行直播监听使用。  
(如果声卡为 $\Phi$ 3.5mm规格的耳机接口，则无需使用转换头，可直接接入使用)

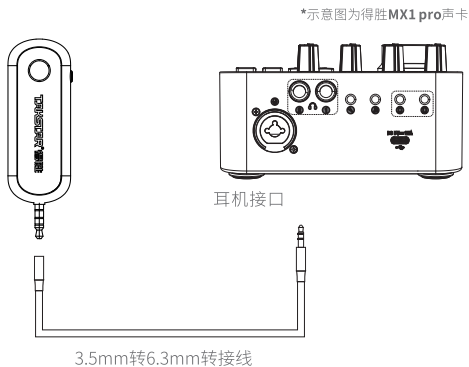

注：为避免信号干扰，使用手机蓝牙功能连接声卡使用时，需增加接入3.5mm延长线再与声卡连接。

### ■ 安全警示

为避免电击、高温、着火、辐射、爆炸、机械危险以及使用不当等可能造成的人身伤害或财产损失，使用本产品前，请仔细阅读并遵守以下事项：

1. 使用产品时请确认所连接设备与本产品是否匹配以及合理调整设备音量大小，不要在超过产品功率及大音量下长时间使用，以免造成产品异常；
2. 使用中若发现有异常（如冒烟、异味等），请立即关闭电源开关并拔掉电源插头，然后将产品送经销商检修；
3. 本产品及配件都应放置在室内干燥通风处，勿长期存放在潮湿、灰尘多的环境中避免靠近火源，雨淋、进水、过度碰撞、抛掷、振动本机及覆盖通风孔，避免损坏其功能；
4. 使用该产品时需遵守相关安全规定，法律法规明确禁止使用场合请勿使用产品以免导致意外事故；
5. 请不要自行拆机改装或维修，以防止出现人身伤害，如有问题或服务需求请联系当地经销商跟进处理。

### ■ 关于图标含义解释



此符号表示，根据WEEE指令(2012/19/EU)和国家法律，由于这种类的废弃物会有潜在的有害物质，可能对环境 and 人类健康产生负面影响，所以本产品不应与您的家庭垃圾一起处置，应将本产品交由授权的电气和电子设备（WEEE）回收站回收。同时，您在正确处理本产品的同时将有助于自然资源的有效利用。如需了解更多有关您可以在何处放置废物回收设备的信息，请联系您当地的城市办事处、废物管理局或家庭废物处理服务部门。

### ■ 关于本说明书

本说明书中内容符合截止印刷之日的技术规格。由于得胜公司会不断改进产品，本说明书可能不符合您的特定产品的技术规格。要获取最新版说明书，请访问得胜官网，然后下载说明书文件。技术规格、设备或另售的附件在各个地区可能有所不同，如有问题请与当地得胜经销商确认。如需更多支持和深层产品信息，请浏览得胜官方网站：<https://www.takstar.com/>



### ■ Preface

Dear Customer,

Thank you for purchasing Takstar WPM-500 Wireless Monitor Headphones. In order to better understand and use the product, please read this manual carefully.

If you have any questions or suggestions, please contact our local dealer.

### ■ Features

- Wireless neckband headphones tailor-made for monitoring live stream, recording and the like.
- 2.4GHz wireless transmission, stable and works up to 10m.
- Easily pair multiple headphones in one system for parallel group monitoring.
- Studio monitoring level, synchronized A/V at low latency for smoother streaming and interaction.
- Quick pairing, auto reconnecting without tedious steps.
- HD stereo audio at 48kHz sample rate, with rich and dynamic music performance.
- Designed with wires that loop around your ears for better security during movement.
- Transmitter adopts ø3.5mm audio interface for easy connection with audio device like sound card or mixer.
- Built-in lithium-ion battery, 6~8 hour battery life with 2 hour charging.

## ■ Package Contents

WPM-500 Wireless Headphones.....	1 PRS
WPM-500 Transmitter.....	1 PCS
USB Charging Cable.....	1 PCS
Audio Extension Cable.....	1 PCS
Adapter Plug.....	1 PCS
Silicone Tips.....	3 PCS
User Manual.....	1 PCS

## ■ Applications

- Live e-commerce, monitor live stream and recording

## ■ Specifications

### Transmitter Specifications

- Battery Capacity: Li-Po, 3.7V/450mAh
- Charging Time: about 2.5 hours
- Charging Voltage/Current: DC 5V/300mA
- Transmission Frequency: 2.4GHz

## **WPM-500** Wireless Monitor Headphones

---

- Battery Life: about 6 hours (when fully charged)
- Weight: 22g

### **Receiver Specifications**

- Battery Capacity: Li-Po, 3.7V/240mAh
- Charging Time: about 2.5 hours
- Charging Voltage/Current: DC 5V/200mA
- Battery Life: about 8 hours (when fully charged)
- Frequency Range: 20Hz-20KHz
- Transmission Frequency: 2.4GHz
- Weight: 33g

### **System Specifications**

- Low Latency Distance:  $\geq 10$  meters
- Audio Delay:  $\leq 20$ ms
- Frequency Response: 20Hz-20KHz (@1KHz, -3dB)
- Signal-to-Noise Ratio:  $\geq 80$ dB(A+)
- System Noise Floor:  $\leq -90$ dB(A+)

Note: The above data are measured by Takstar laboratory.

### ■ Function Descriptions

#### Transmitter

- ① Power button: press and hold for 2s to turn on/off the transmitter.  
With device powered on, LED② glows blue;  
once powered off, LED ② goes off.
- ② LED indicator: turns solid red while charging;  
stops glowing red when fully charged;  
flashes red if low battery;  
flashes blue rapidly while pairing and resumes solid blue when paired.
- ③ Pair key: with device powered on, press and hold for 2s to start pairing.

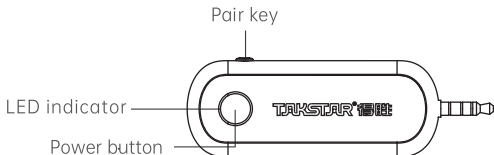

### Wireless Headphones

- ① Power button: press and hold for 2s to turn on/off the headphones.
- ② LED indicator: once powered on, flashes blue slowly while trying to auto reconnect recently paired transmitter, and turns solid blue when reconnected successfully;  
flashes blue rapidly while pairing and resumes solid blue when paired.
- ③ Pair key: with device powered on, press and hold for 2s to start pairing.
- ④ Volume control: press [+] to gradually increase headphone volume, press and hold to increase rapidly;  
press [-] to gradually decrease headphone volume, press and hold to decrease rapidly. There are 10 volume levels in total.

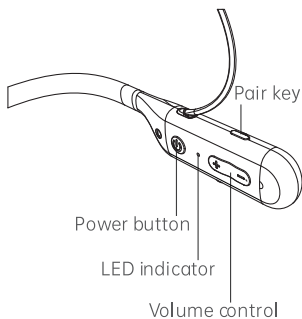

## WPM-500 Wireless Monitor Headphones

---

### Pairing Transmitter & Headphones:

The transmitter and the headphones are already paired before shipping out factory and will auto connect to each other once powered on. However, if any one of them is replaced, follow below steps for pairing:

1. Turn on both the headphones and the transmitter.
2. Press and hold the pair keys on both the headphones and the transmitter for 2s until their LEDs flash rapid blue as they start pairing. Once paired successfully, their LEDs will resume solid blue.

Note: In case of pairing malfunction, try system reset by pressing and holding both the power button and pairing button while connecting the headphones to a Type-C charging cable.

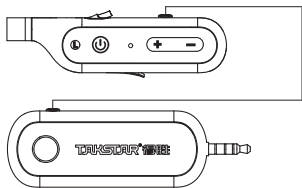

Press and hold either key for 2s. Both LEDs glow blue when paired successfully.

### Monitoring Live Stream:

1. Once the transmitter and headphones are paired successfully, insert the supplied 3.5mm-to-6.3mm adapter plug into the headphone output of your audio interface.

## WPM-500 Wireless Monitor Headphones

---

2. Insert the transmitter into the adapter plug to start monitoring your live stream.

(The adapter plug is not necessary if the audio interface has a  $\varnothing 3.5\text{mm}$  headphone output.)

\* Illustrated model is Takstar MX1 Pro Mixer

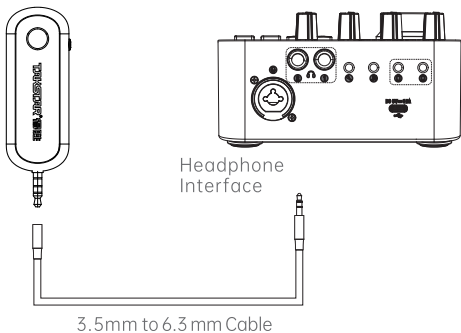

Note: In order to avoid signal interference, when your audio interface is connected to smartphone via Bluetooth, you need to add a 3.5mm extension cable in between the transmitter and the audio interface.

### ■ Safety Instructions

To avoid electric shock, overheat, fire, radiation, explosion, mechanical risk and injury or property loss due to improper use, please read and observe the following items before use:

## **WPM-500** Wireless Monitor Headphones

---

1. Please check if the power of the connected equipment matches with that of this product before operation. Adjust the volume to proper level during operation. Do not operate at over-power or high-volume level for extended time to avoid product malfunction or hearing impairment.
2. If there is any abnormality during use (e.g., smoke, strange odor), please kill the power switch and unplug from power source, then send the product to the local dealer for repair.
3. Keep this product and its accessories in a dry and ventilated area. Do not store in a humid or dusty area for extended time. Keep away from fire, rain, liquid intrusion, bumping, throwing, vibrating, or from blocking any ventilation openings, to prevent malfunction.
4. Please abide by safety rules during operation. Do not use the product in places prohibited by laws or regulations to avoid accident.
5. Do not disassemble or repair the product by yourself to avoid injury. If you have any questions or require any services, please contact our local dealer.



### ■ Label Meanings



This symbol indicates that this product should not be disposed of with your household waste, according to the WEEE directive (2012/19/EU) and your national law. This product should be handed over to an authorized collection site for recycling waste electrical and electronic equipment (WEEE). Improper handling of this type of waste could have a possible negative impact on the environment and human health due to potentially hazardous substances that are generally associated with WEEE. At the same time, your cooperation in the correct disposal of this product will contribute to the effective usage of natural resources. For more information about where you can drop off your waste equipment for recycling, please contact your local city office, waste authority, or your household waste disposal service.

### ■ About This Manual

This manual contains up-to-date technical specifications as of printing. However, specifications contained herein may not conform to your particular product since Takstar is constantly improving its products. Also, specifications, devices or accessories available may vary from region to region. If you have any questions, please contact our local dealer. For the latest version/more information, please visit our website:

<https://www.takstar.com/>

## 注意事项:

1. 本单为保修凭证, 请用户妥善保管, 如有遗失, 恕不保修或退换。
2. 保修期限制: 购买之日起十二个月内。
3. 除了不可抗力事件损坏外, 由本公司负责, 免费维修。
4. 如属保管不善或使用不当造成的损坏, 维修点将酌情收费。
5. 擅自拆卸维修者, 不予保修。
6. 以上保修条款仅限于中国市场适用 (不含港澳台地区)。

## 产品服务保证书

姓名: \_\_\_\_\_ 电话: \_\_\_\_\_ 地址: \_\_\_\_\_

商品: \_\_\_\_\_ 型号: \_\_\_\_\_ 购买日期: \_\_\_\_\_ 年 \_\_\_\_ 月 \_\_\_\_ 日

维修记录栏 (由维修员填写)	维修员签名	日期



扫一扫，了解更多产品  
Scan for more  
product information

## **广东省电声工程技术研究开发中心 广东得胜电子有限公司制造**

地址：广东省惠州市博罗县龙溪街道富康一路2号

服务热线：400 6828 333 传真：0752 6383950

邮箱：xs@takstar.com

网址：www.takstar.com

Guangdong Takstar Electronic Co., Ltd.

Address: No. 2 Fu Kang Yi Rd., Longxi Boluo

Huizhou, Guangdong 516121 China

Tel: 86 752 6383644 Fax: 86 752 6383952

Email: sales@takstar.com

Website: www.takstar.com